

General Description

Series SE60 is a two stage, 4-way, flapper and nozzle style servovalve. The SE60 has a wide range of flow ratings and a high performance spool and sleeve design.

A special jewel feedback design enhances durability and prevents ball glitch problems, which can occur in other types of servovalves. This valve is rated for 210 Bar (3000 PSI) service.

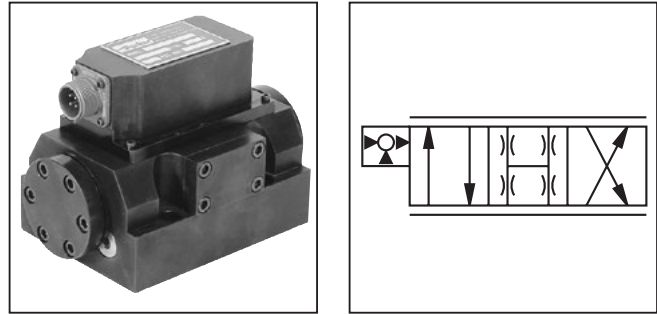

Features

- Lapped spool and sleeve
- Jewel feedback ball for durability
- Aluminum body
- Medium and High performance
- ISO 10372 size 6 standard 50.8 mm (2.000 in.) port circle

Specifications

Flow Rating ±10% @ 70 Bar (1000 PSI)	95, 150, 230 LPM (25, 40, 60 GPM)
Supply Pressure	10 – 210 Bar (145 – 3000 PSI)
Tank Port Pressure	210 Bar (3000 PSI) Max. < 10 Bar (145 PSI) for best performance
Null Leakage Flow per 70 Bar (1000 PSI)	2.4 – 3.6 LPM (0.6 – 1.0 GPM)
Pilot Flow @ 210 Bar (3000 PSI)	0.4 LPM (0.1 GPM)
Input Command	±40 mA std.
Frequency Response @ 90° phase shift	> 100 Hz (See Performance Curves)
Non-Linearity	≤ 10%
Hysteresis	≤ 4%
Threshold	≤ 1%
Null Shift with temperature with pressure	≤ 2% per 55°C (100°F) ≤ 2% per 70 Bar (1000 PSI)
Pressure Gain change in pressure per 1% change in input command	60% typical
Step Response	0 - 100%, < 15 ms
Fluid	Petroleum based Mineral Oil, 10 – 110 cSt at 38°C (100°F)
Fluid Cleanliness	ISO 4406 15/12 or better
Operating Temperature	-30°C to +130°C (-22°F to +266°F)
Protection Class	NEMA 4, IP65

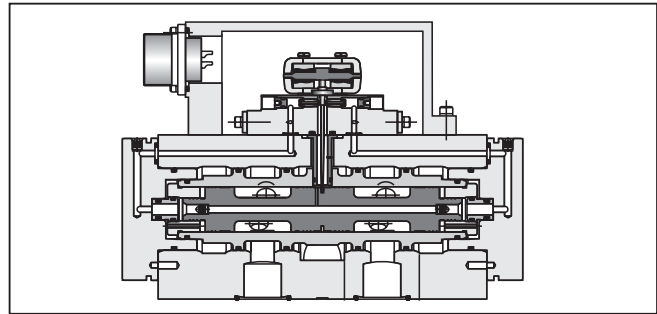

Flow vs. Pressure Drop

at 100% command
 Flow Path P → C1 → C2 → R

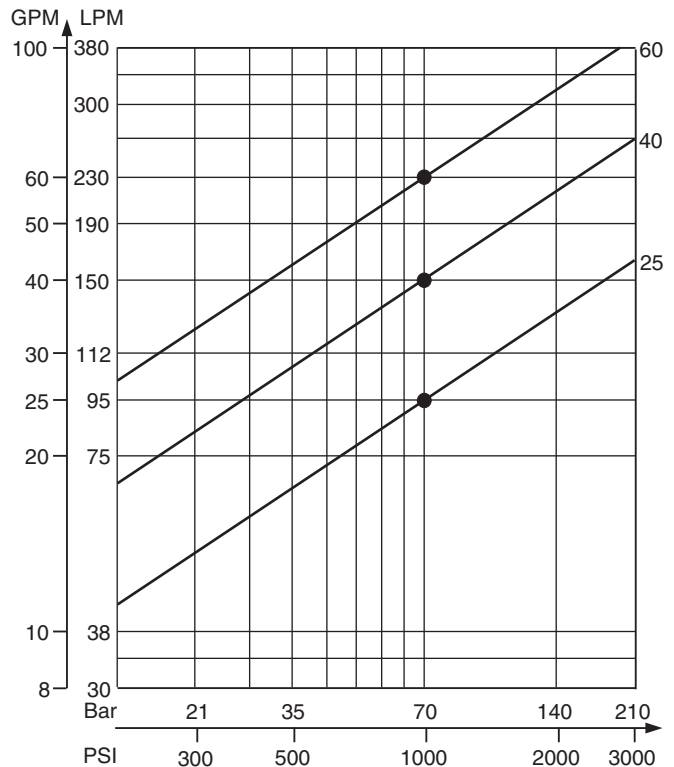

WARNING: This product can expose you to chemicals including Lead, Nickel (Metallic), or 1,3-Butadiene which are known to the State of California to cause cancer, and Lead or 1,3-Butadiene which is known to the State of California to cause birth defects and other reproductive harm. For more information go to www.P65Warnings.ca.gov.

C01_Cat2550.indd, ddp, 04/19

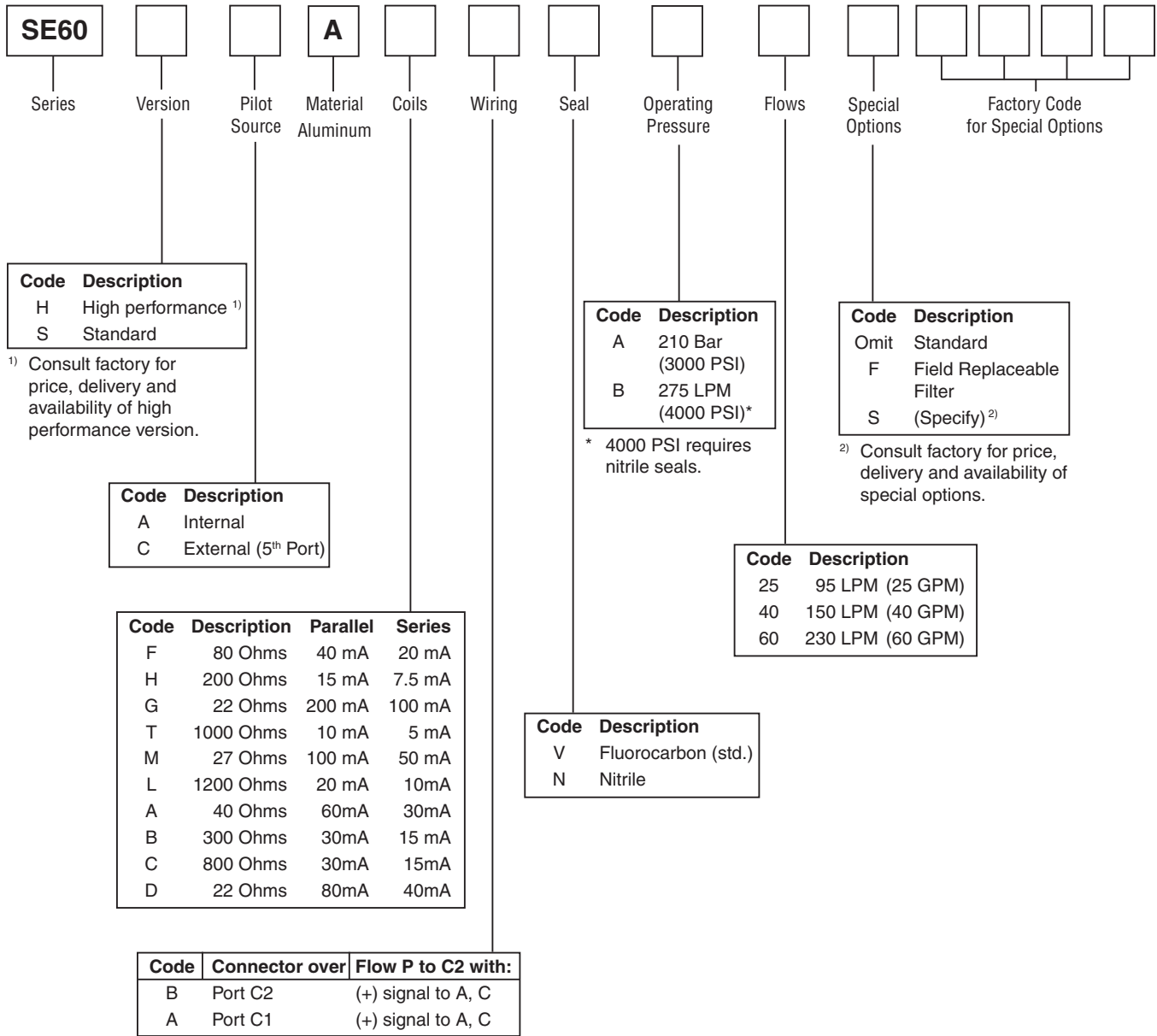

Weight: 3.4 kg (7.5 lbs.)
Cable with mating connector: EHC154S
Mating connector: MS3106E-14S-2S
Bolt kit: 4 of M10 x 60 mm, or 4 of 3/8-16x2.375"
Flushing valve: Consult factory. Use 1278007 and 11-0700.
US Subplate, 4 ports: AS06SPS20S (# 20 SAE side ports)
Metric Subplate, 4 ports: AS06SPS20M (M42 x 2.0 ISO 6149 side ports)
Electronics: BD101, 23-7030, BD90, or BD95

Performance Curves

Frequency Response at 210 Bar (3000 PSI)

Standard Response

SE60 – 95 LPM (25 GPM)

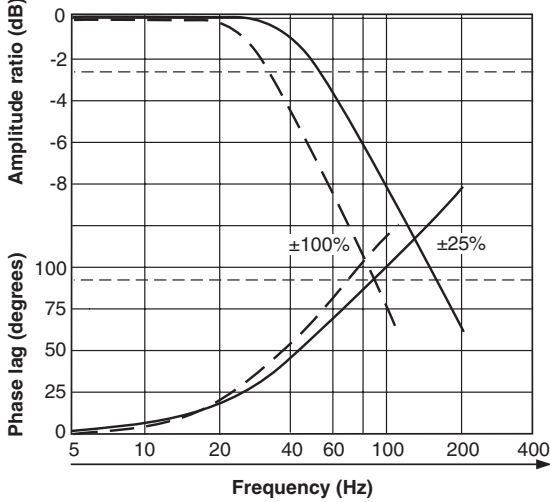

High Response

SE60 – 230 LPM (60 GPM)

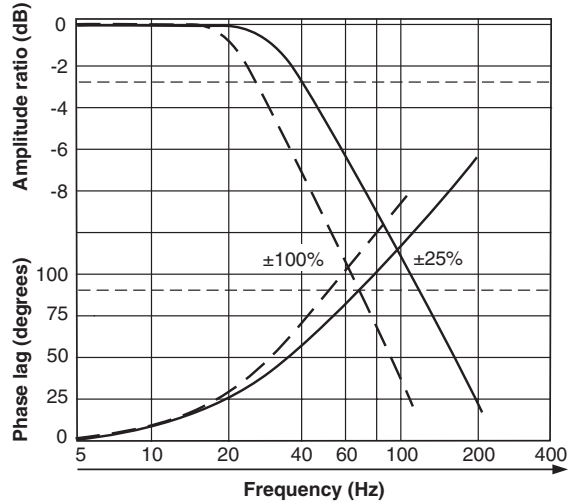

Step Response at 210 Bar (3000 PSI)

Standard Response

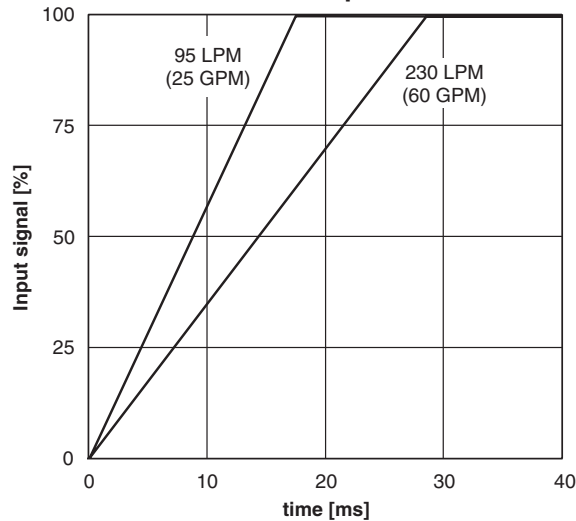

Installation Wiring Options

This servovalve has two coils. When connecting the valve to a drive amplifier, the user's external wiring may put the coils either in parallel or in series as needed. Refer to the illustrations below and to the mounting pattern for this valve to insure proper control phasing.

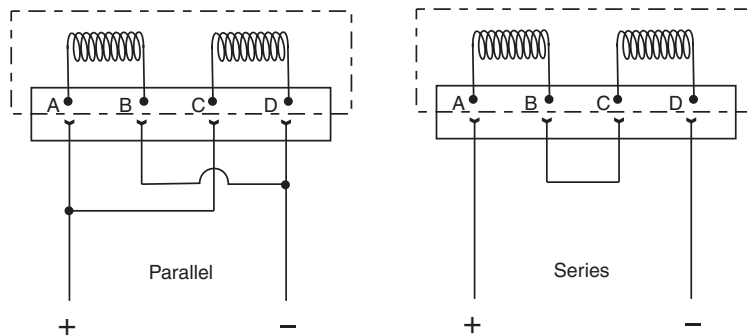

Polarity shown connects flow from P to C2 port.

Dimensions

Servovalves Series SE60

Inch equivalents for millimeter dimensions are shown in (**)

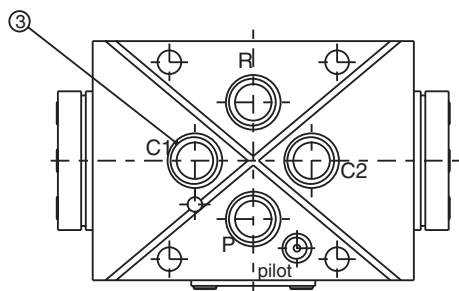
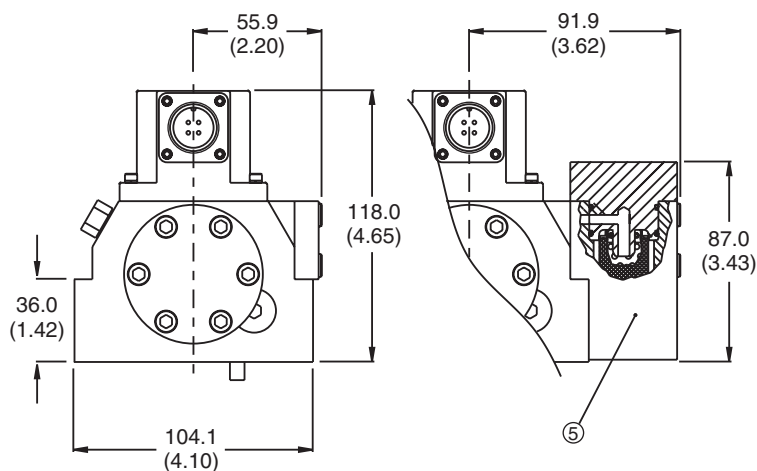
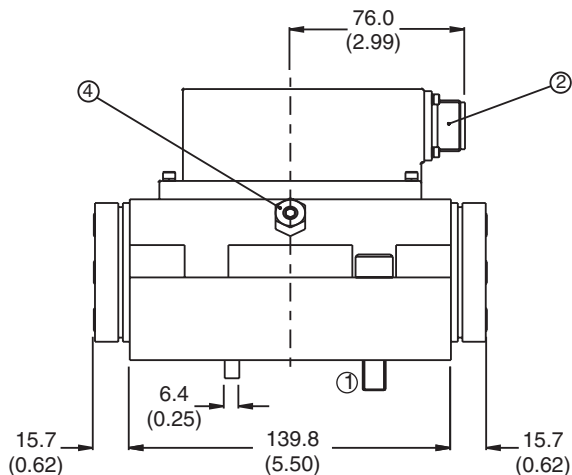

1. Suggested mounting bolts M10 x 60 mm or 3/8-16 x 2.375" long high tensile steel, socket-head cap screws.
2. 4-way electrical connector mates with MS3106-14S-2S or equivalent. Is available at 180° to position shown (advise desired position at time of order).
3. Base O-Rings: 4 of Parker 2019V-7, 1 of Parker 2012V-7 (if external pilot is used).
4. Null adjust requires 12 A/F ring spanner (12 mm box end wrench) and 3.0 hexagon key. Flow out of C2 will increase with clockwise rotation of key.
5. Optional field replaceable filter housing. Element P/N SRS1479.

Mounting Surface

1. The minimum depth of hole G is 2 mm (0.079 in.). The ISO recommended full-thread depth is 30 mm (1.181 in.).
2. Surface roughness Ra < 0.8 μm [N6], as specified in ISO 468 and ISO 1302.
3. Surface flatness: 0.025 mm (0.001 in.) as specified in ISO 1101.

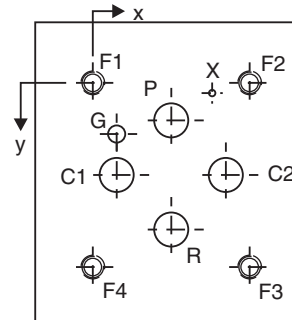

Metric Dimensions (mm)						(± 0.1 mm)				
Axis	P	C1	R	C2	G	X	F1	F2	F3	F4
		∅ 17.5 max	∅ 17.5 max	∅ 17.5 max	∅ 17.5 max	∅ 8	∅ 5	M10	M10	M10
x	36.5	11.1	36.5	61.9	11.1	55.6	0	73.0	73.0	0
y	17.4	42.8	68.2	42.8	23.7	4.7	0	0	85.7	85.7

U.S. Dimensions (inches)						(± 0.004 in.)				
Axis	P	C1	R	C2	G	X	F1	F2	F3	F4
		∅ 0.688 max	∅ 0.688 max	∅ 0.688 max	∅ 0.688 max	∅ 0.39	∅ 0.20	3/8 - 16	3/8 - 16	3/8 - 16
x	1.437	0.437	1.437	2.437	0.437	2.187	0	2.875	2.875	0
y	0.687	1.687	2.687	1.687	0.937	0.187	0	0	3.375	3.375

